

Flying Saucers-For Real!

(The secret truth behind U.S. built flying wing disc aircraft)

All Rights Reserved

By Jack D. Pickett and Michael H. Schratt

February 2003

Illustrations by Michael H. Schratt

and

Gino Marcomini



TOP SECRET



(Illustration #1)

What you are about to read is still classified "TOP SECRET" by the United States Air Force. Now, after 60 years, the true story of the U.S. involvement into the design and construction of "Flying Saucers" can now finally come to light. This is not your run-of-the-mill "light in the sky" saucer story. In this case, the dates, names, and locations of very specific personnel and hardware can now be identified, which point to a very "terrestrial" explanation for many of the "UFO" sightings beginning since 1947.

THE REAL STORY: The case for U.S. built flying wing disc aircraft (aka flying saucers) begins with an unprecedented true account by Mr. Jack D. Pickett (retired WWII combat veteran and publisher). During the 1960's, and on into 1972, Jack Pickett and his business associate Harold Baker published for the Air Force certain house-organ magazines (club-calendar-events) for NCO and Officer's Club facilities for several military bases in Florida. It was 1967 when the Adjutant General's Office at MacDill AFB (Tampa Florida) proposed a front cover, and two-and-a-half page article within. The subject was Vintage, Historical or Experimental aircraft.

THEY DO EXIST: Jack and Harold learned that some experimental jet aircraft were being stored at the base salvage/scrap-yard (see picture 2, illustration 3 & 4). These particular aircraft had already been decommissioned/declassified, and were parked directly outside, and NOT in a hangar. In September of 1967, both Jack and Harold drove together to where these aircraft were being parked. Upon arriving at the chain link fence, which surrounded the perimeter of the base near the scrap-yard, Jack first saw the most awe-inspiring aircraft ever built. Jack's initial thought was: "My gosh! Those are Flying Saucers! Those things really do exist!". There, parked outside on a taxi-way near the base scrap-yard, were four flying wing discs, measuring 20, 40, 70 and 116 feet in diameter (see arrow MacDill AFB aerial photo #2). Jack recalled that the chain link fence was only 50 feet from where the discs were parked. Because they were the last remaining of their model, the Master Sergeant of the Non-Commissioned Officer's Club telephoned the Adjutant General's Office for permission for polaroid photographs to be taken, even though all of the tires were completely flat down to their wheel rims. The Master Sergeant stated to Jack that he was not sure what these aircraft were for, but thought they might be some sort of "test" aircraft. The General's Office suggested that Jack use higher quality official Air Force photographs available at the Adjutant General's library at MacDill. Apparently, the Air Force wanted to make a good impression, and did not want to release photos of these aircraft with flat tires and at least one sagging landing gear strut (see sub-heading Large Disc). Jack was also informed that it would not take long to bring these aircraft back up to "flying status". Jack Pickett was issued for his article, the highest security clearance ever given to any civilian publisher due to his prior work with SAC/TAC/Navy/Army bases. Under armed military guard, Jack was personally shown literally hundreds of official U.S.A.F. photographs of these aircraft in formation flight, on the tarmac, and was shown portions of motion picture footage of these aircraft in flight (see aerial photos/illustrations 13-18). Jack was allowed to select those photographs best suited for the up-coming NCO Club newsletter article, and obtain additional detailed information concerning the discs. It's important to note, that these four aircraft are NOT to be confused with the well known Avro VZ-9 Avrocar, Chance Vought V-173 "Flying Pancake", Project Silverbug, or the Chance Vought XF5U-1.





(Illustration #2)



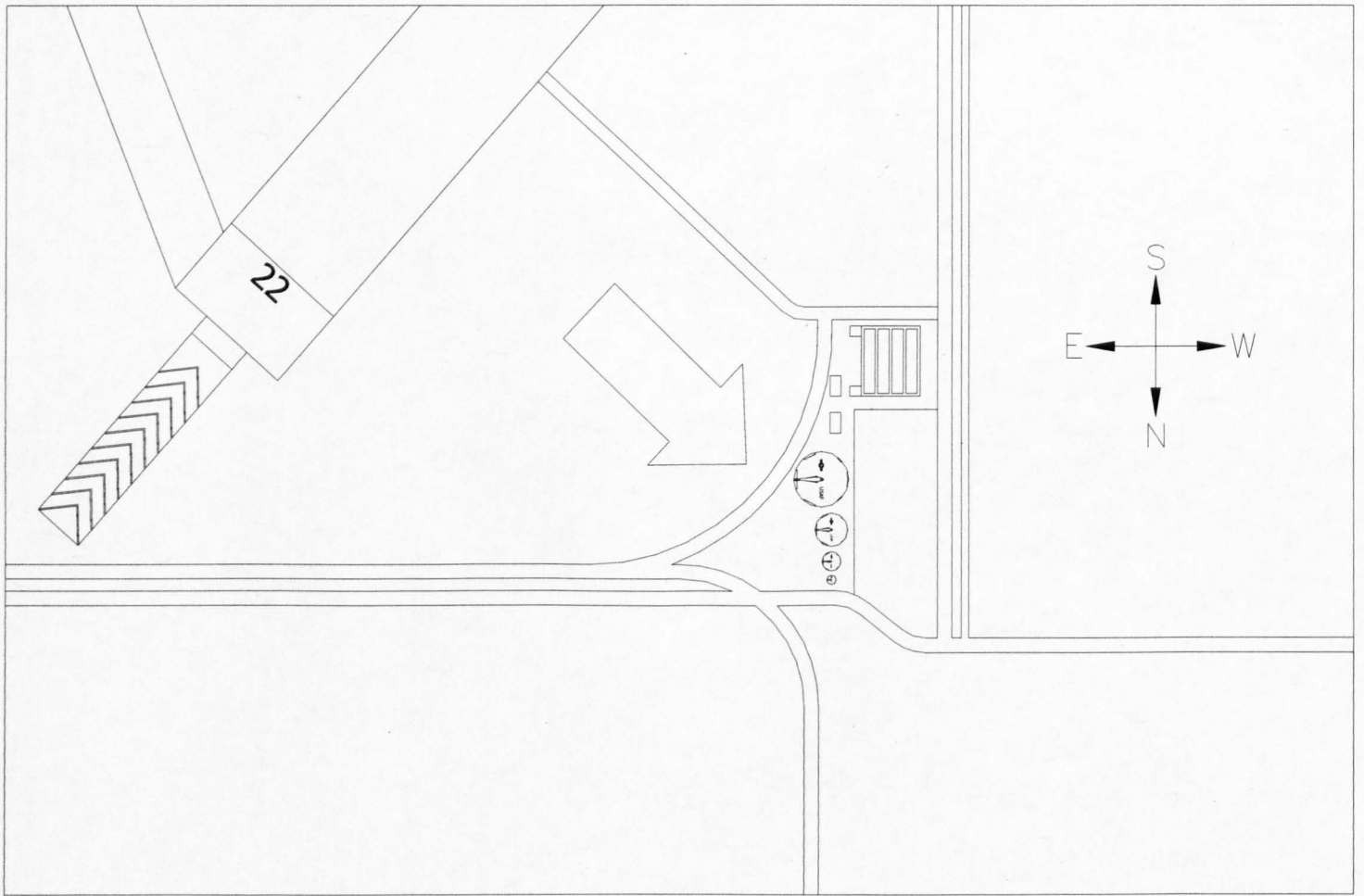

(Illustration #3)

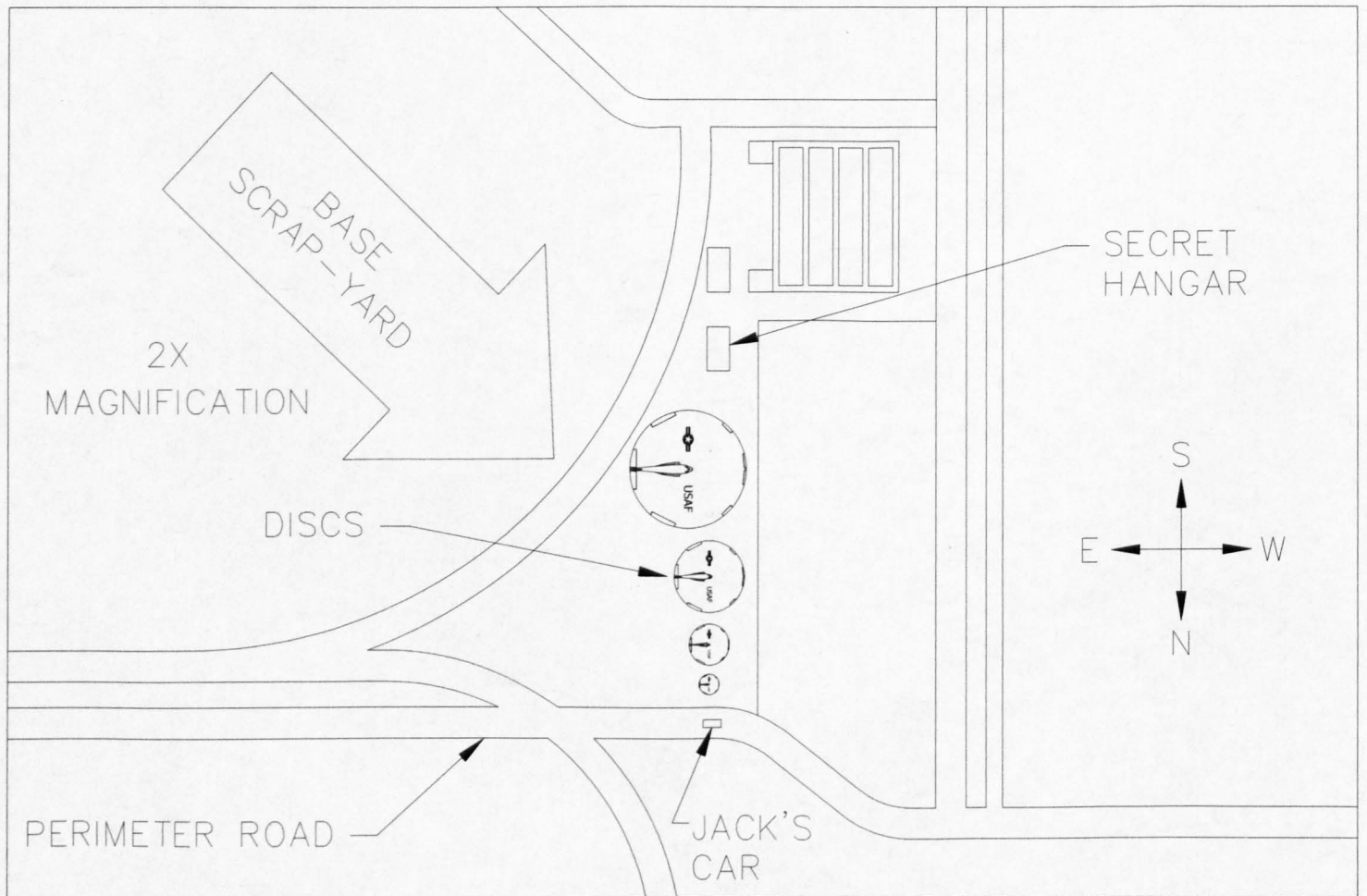

(Illustration #4)

"FLYING SAUCERS FOR REAL !!"
'ULTRA TOP SECRET USAF JET FLYING WING DISC'
 STATIONED AT MacDILL AFB - 1967

DIAMETER.....20 FT. & APPROX. 40 FT.
 MAX SPEED.....629 MPH.
 POWERPLANT.....(2) TURBO-JET ENGINES ?
 RANGE.....1,200 MILES
 CREW.....1
 CEILING.....60,000 FT.
 FIRST FLIGHT.....1944 (DRESDEN) 1955 (USA) ?
 CONTRACTOR.....BMW/HEINKEL
 AVRO (CANADA-U.S. GOVT.)

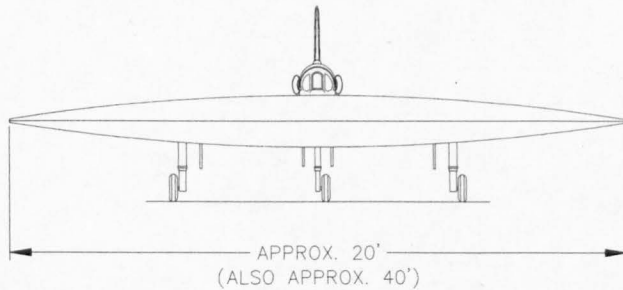
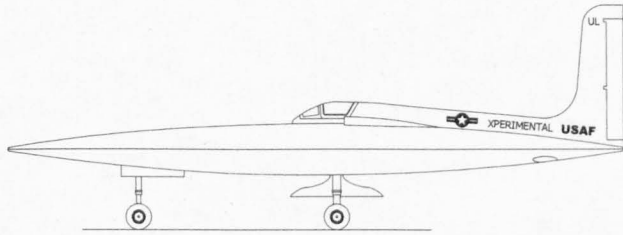

THIS ILLUSTRATION AND ITS CAPTIONS ARE PROTECTED UNDER COMMON-LAW COPYRIGHT BY MICHAEL H. SCHRATT, AND JACK PICKETT. ALL RIGHTS ARE RESERVED. REPRODUCTION OF THIS DOCUMENT IN ANY MEDIA, STORAGE IN ANY DATA RETRIEVAL SYSTEM, OR TRANSMISSION OF THIS IMAGE WITHOUT THE EXPRESS WRITTEN PERMISSION OF THE ENGINEER/AUTHORS IS PROHIBITED, AND SUCH PROTECTION EXTENDS FROM JUNE OF 2002. REQUESTS MAY BE DIRECTED TO THE ENGINEER/AUTHORS/ IN CARE OF : MICHAEL H. SCHRATT, 215 LAKE SHORE DR. CRYSTAL LAKE IL, 60014

ULTRA TOP SECRET USAF JET FLYING WING DISC	
DRAWN BY: MICHAEL H. SCHRATT	DATE: FEB 10, 2003
AIRCRAFT EXAMINED BY: JACK D. PICKETT	DATE: 1967

"FLYING SAUCERS FOR REAL !!"
'ULTRA TOP SECRET USAF JET FLYING WING DISC'
 (STATIONED AT MacDILL AFB - 1967)
 (ALSO SEEN AT WPAFB HANGAR #4 - 1978)

DIAMETER.....116 FT.
 MAX SPEED.....629 MPH.
 POWERPLANT.....(4) TURBO-JET ENGINES ?
 RANGE.....3,000 MILES
 CREW.....5 TO 7
 CEILING.....60,000
 FIRST FLIGHT.....1944 (DRESDEN) 1955 (USA) ?
 CONTRACTOR.....BMW/HEINKEL
 AVRO (CANADA-U.S. GOVT.)

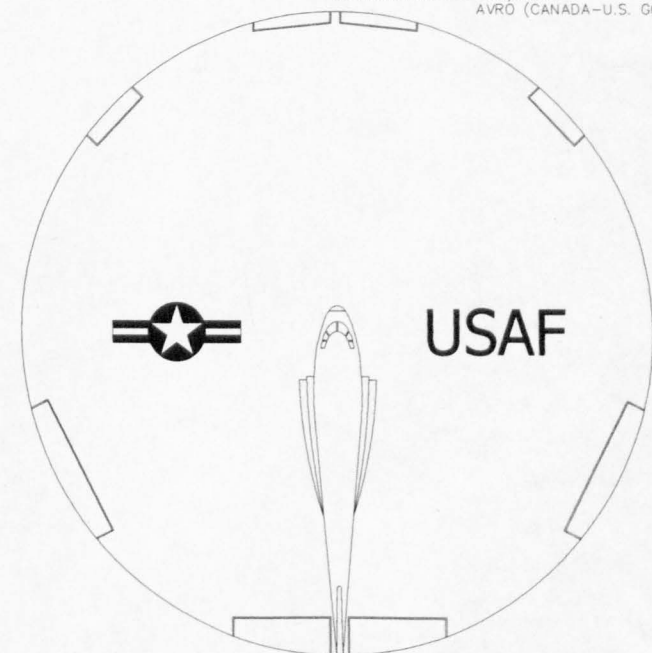
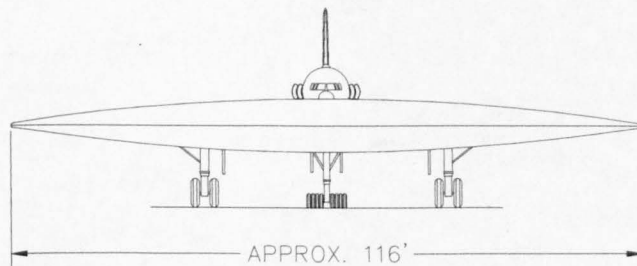
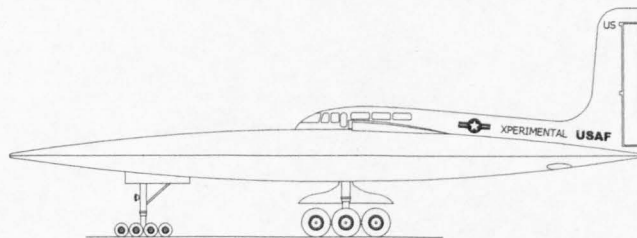

THIS ILLUSTRATION AND ITS CAPTIONS ARE PROTECTED UNDER COMMON-LAW COPYRIGHT BY MICHAEL H. SCHRATT, AND JACK PICKETT. ALL RIGHTS ARE RESERVED. REPRODUCTION OF THIS DOCUMENT IN ANY MEDIA, STORAGE IN ANY DATA RETRIEVAL SYSTEM, OR TRANSMISSION OF THIS IMAGE WITHOUT THE EXPRESS WRITTEN PERMISSION OF THE ENGINEER/AUTHORS IS PROHIBITED, AND SUCH PROTECTION EXTENDS FROM JUNE OF 2002. REQUESTS MAY BE DIRECTED TO THE ENGINEER/AUTHORS/ IN CARE OF : MICHAEL H. SCHRATT, 215 LAKE SHORE DR. CRYSTAL LAKE IL, 60014

ULTRA TOP SECRET USAF JET FLYING WING DISC	
DRAWN BY: MICHAEL H. SCHRATT	DATE: AUG 23, 2002
AIRCRAFT EXAMINED BY: JACK D. PICKETT	DATE: 1967

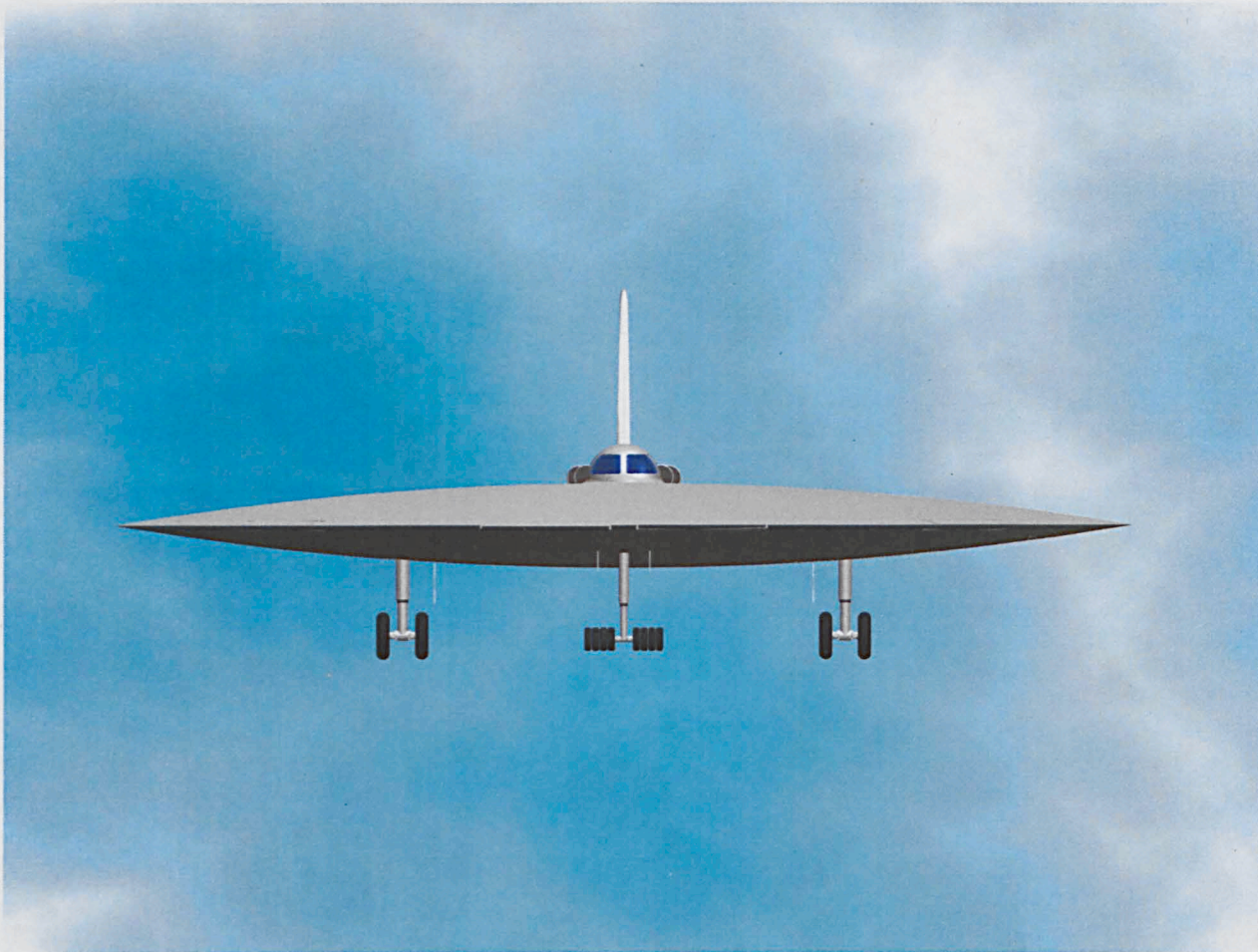

(Illustration #7)

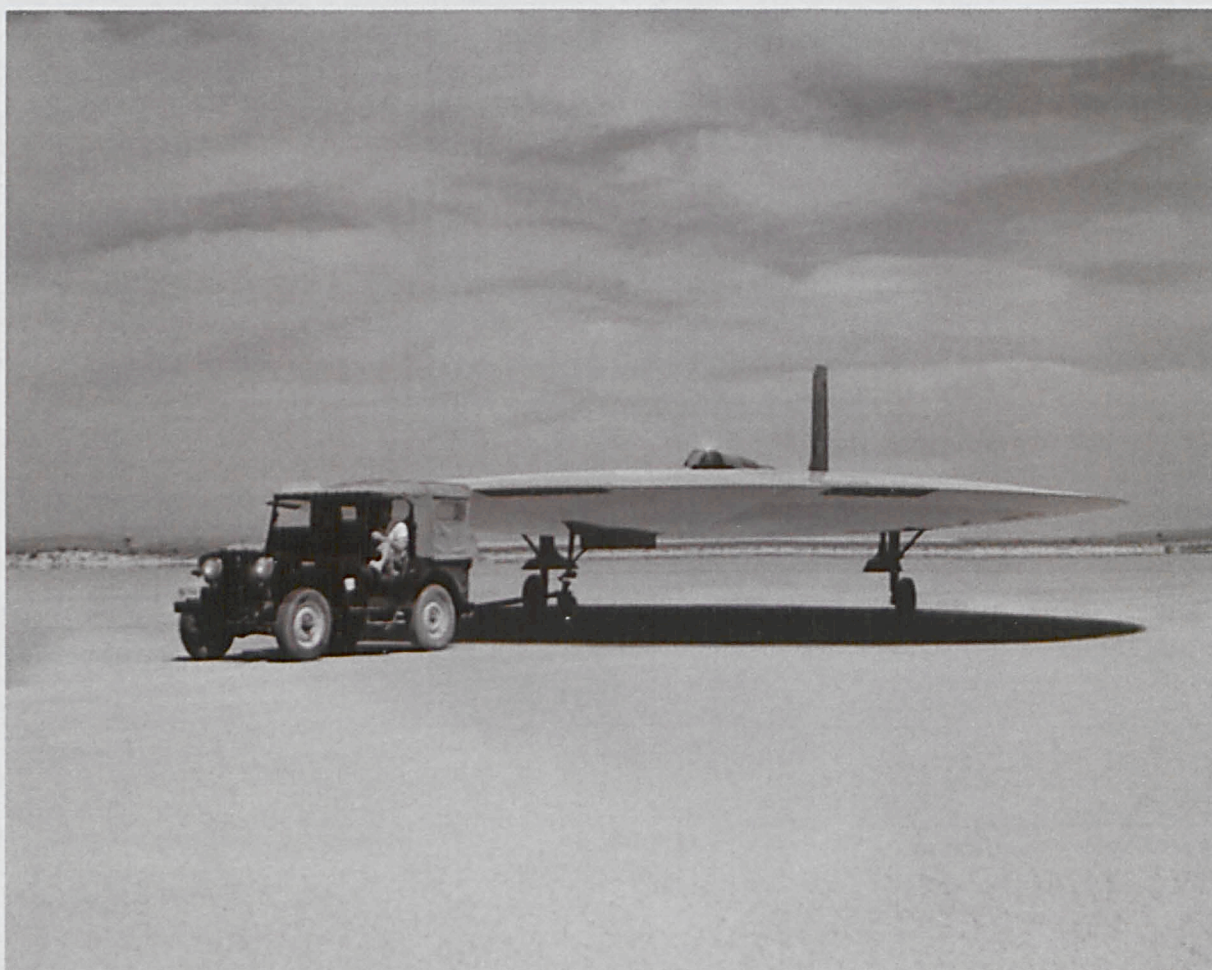

(Illustration #8)



(Illustration #9)

DECLASSIFIED

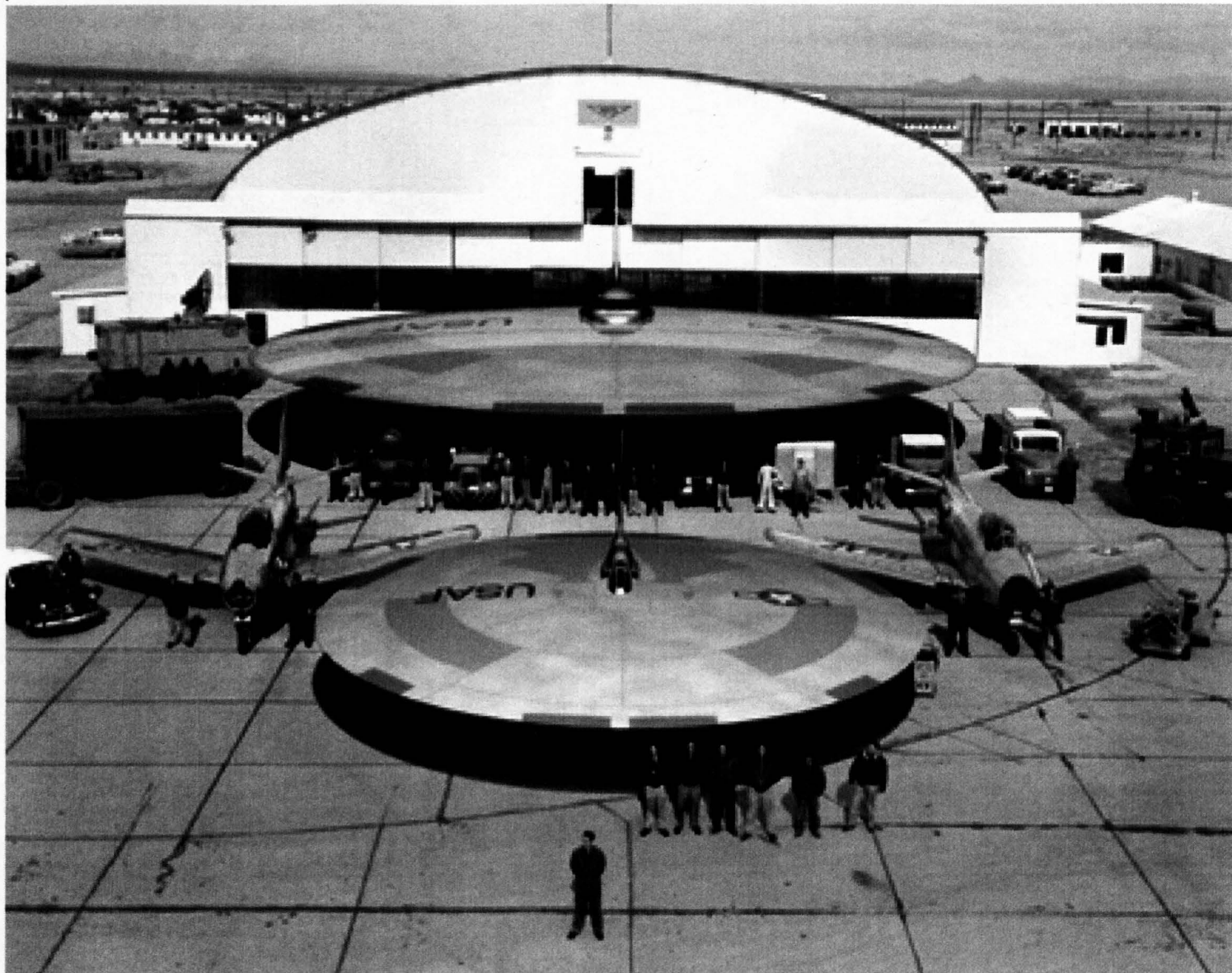

(Illustration #10)

DESCRIPTIONS OF THE DISCS: Authors special note: It's important to note that when describing the outward appearance of these aircraft, all aviation researchers and historians should 100% discard all of their pre-conceived ideas of what an aircraft should look like. When Jack first saw the official USAF photos of these aircraft, he was amazed, and immediately asked questions regarding how large, and how many of these aircraft were built. Jack also inquired about the flight performance (altitude and cruise speed) for these aircraft. Some of the in-flight photos clearly showed the discs being escorted by an F-84F Thunderstreak (swept-wing) interceptor aircraft (see aerial photos/illustrations 1 and 11-14). A few of the in-flight photos also appeared to show F-80 Shooting Star, F-86 Saber and F-100 Super Saber jet aircraft. Some of the photos that Jack was shown included 50 aircraft flying in formation. Authors special note: The specific USAF squadron that flew chase for these discs carried the unique designation "FLITAFF" (Fighter Long-range Tactical Air-command Future Forces) see illustrations 20 & 21. This support group (SG) was at one time stationed at Carswell AFB (Fort Worth Texas), than later transferred to James Connolly AFB (Waco Texas). Indeed, "FLITAFF" was actually painted on a hangar at James Connolly AFB. Looking head on, they appeared as the classic so-called "Flying Saucer" shape, very similar to two saucers stacked one over the other (see illustration #7). The pilot/crew compartment appearing as a bubble shaped contour located directly in the middle of the top of the disc. There was nothing forward of the pilot's compartment other than the sloping surface. That compartment, featured a "spinal fairing" that ran from the canopy, and tapered back towards the trailing edge of the disc, narrowing down to a very high vertical tail. The small 20' diameter craft (see illustration #5) had a crew of one, with an air-intake on both sides of the pilot's compartment, and two exhaust ports at the aft lower portion of the disc. The air-intakes could best be described as looking very similar to that of a Harrier or Douglas A-7 Skyhawk. This aircraft also employed

control surfaces along the circumference of the disc. Jack also recalled that all four aircraft had a small black "non-slip" walk-way that ran along the length of the fuselage, leading up to the pilot/crew compartment. According to Jack, the smaller disc seemed to incorporate a sort of magnifying/enlarging optical sight, which was directly embedded into the 1-1/2 to 2" thick canopy windows, which may also have been used as a flat armored glass windscreen. The standard Air Force insignia, and the designation "XPERIMENTAL" followed by "USAF", was visibly printed starting immediately behind the windows of the compartment on towards the tail. On the upper surface of the vertical stabilizer, there was the identification "U.L." which stood for "Unlimited Altitude". Jack was informed that the discs had considerable various uses. The O.I.C. permitted Jack to actually kick the tires of the smaller 40' craft, while the O.I.C. stood nearby and snapped a photo in the process. The 40' disc featured a hinged canopy that flipped up to allow entry for the pilot. All four discs were polished aluminum silver in color, with the aircraft skin seams and rivets clearly visible. Jack recalled that the aircraft "skin" was in good condition, and did not show signs of excessive oxidized wear. He was also permitted to run his hand along the edge of the smaller discs. Amazingly, each aircraft was so exceedingly streamlined that it appeared as though each craft were made out of one piece. The discs themselves, regardless of size, all had tricycle landing gear. The size of the aircraft, determined how many wheels on each. According to the O.I.C. (Officer in charge) of MacDill, all four aircraft had been flown in, and then immediately parked outside at the scrap-yard. The O.I.C. also informed Jack that not one person had ever been allowed to enter any of the discs since they arrived.

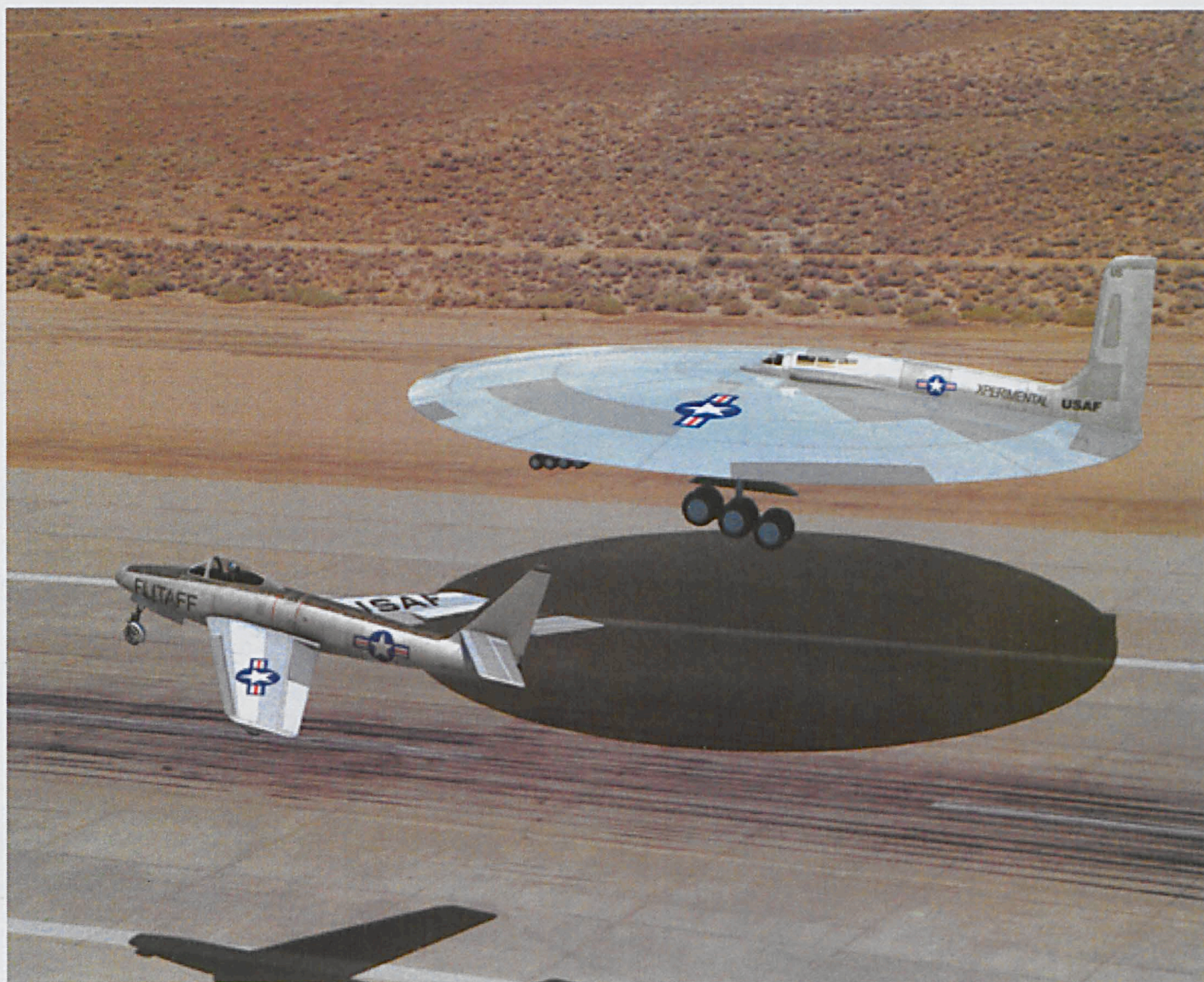

(Illustration #11)

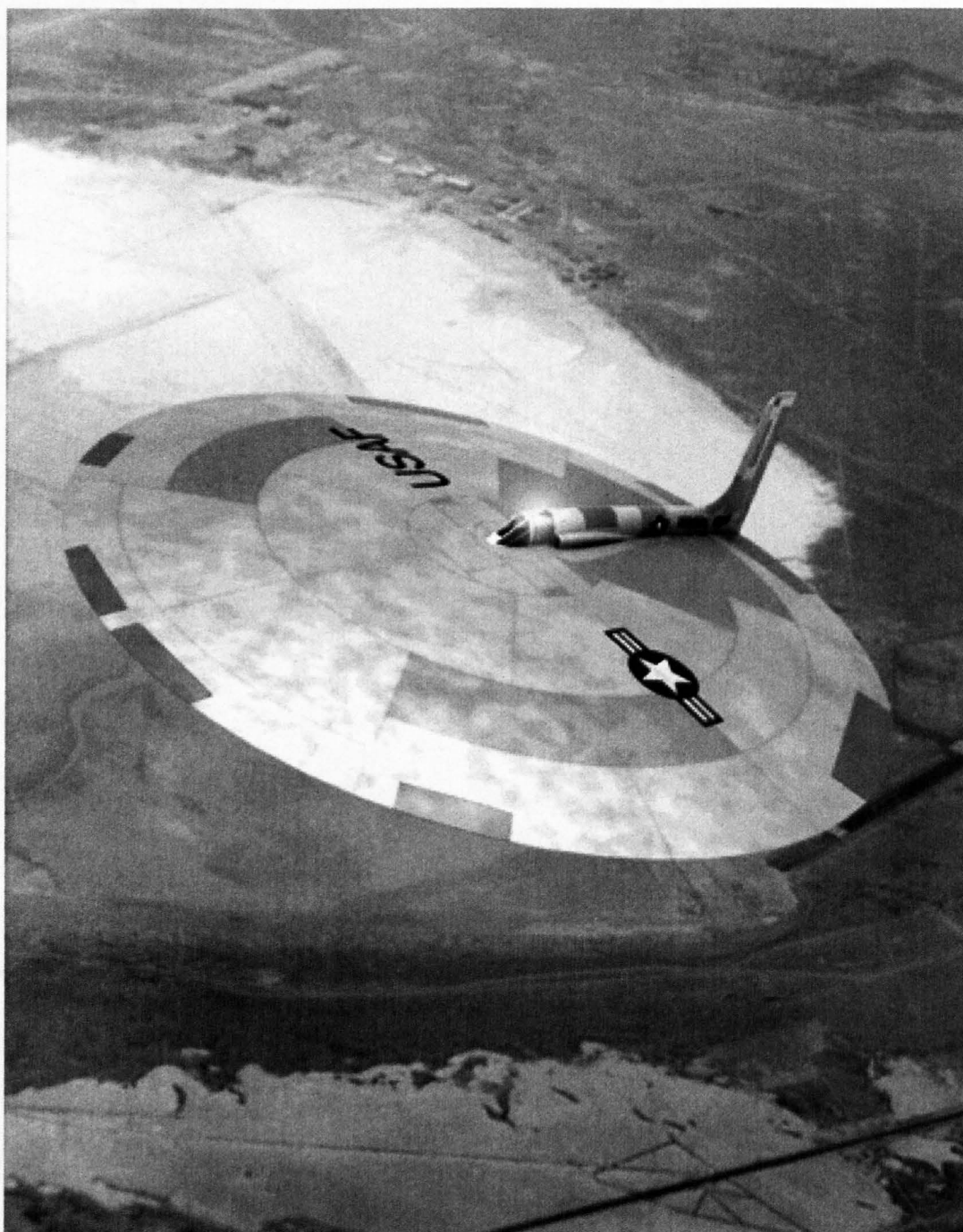

(Illustration #12)

EYES ONLY

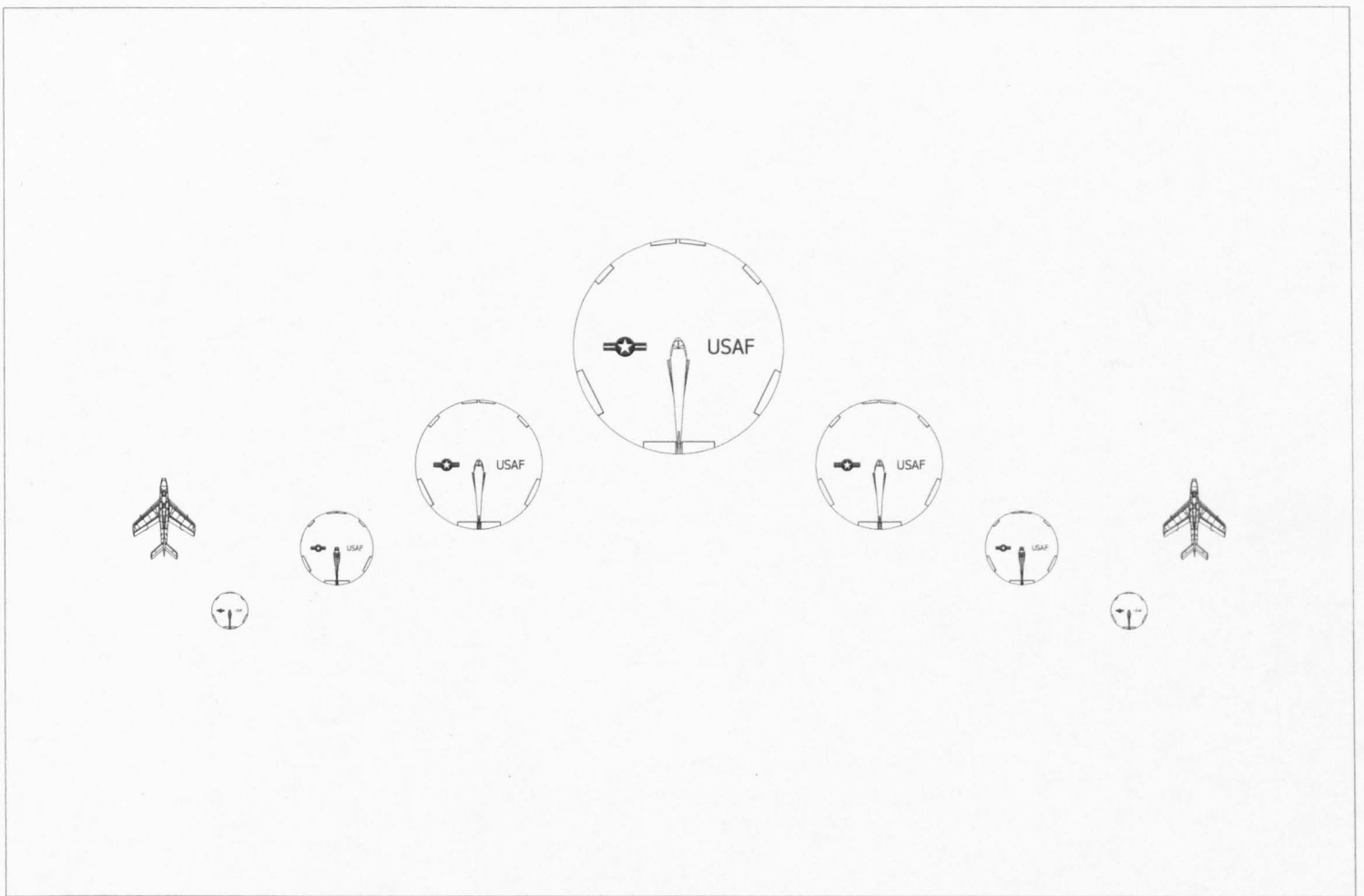

(Illustration #13)

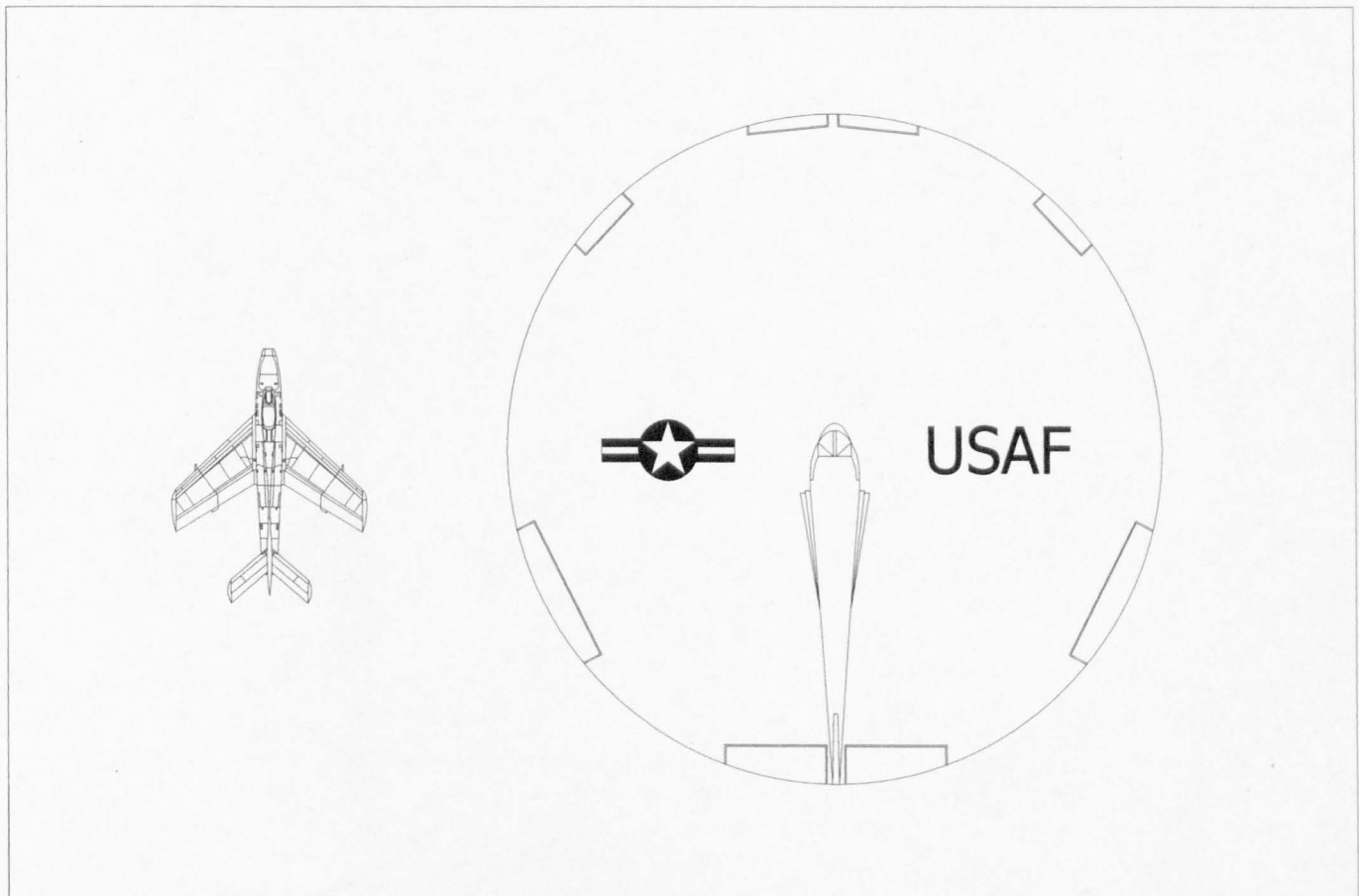

(Illustration #14)

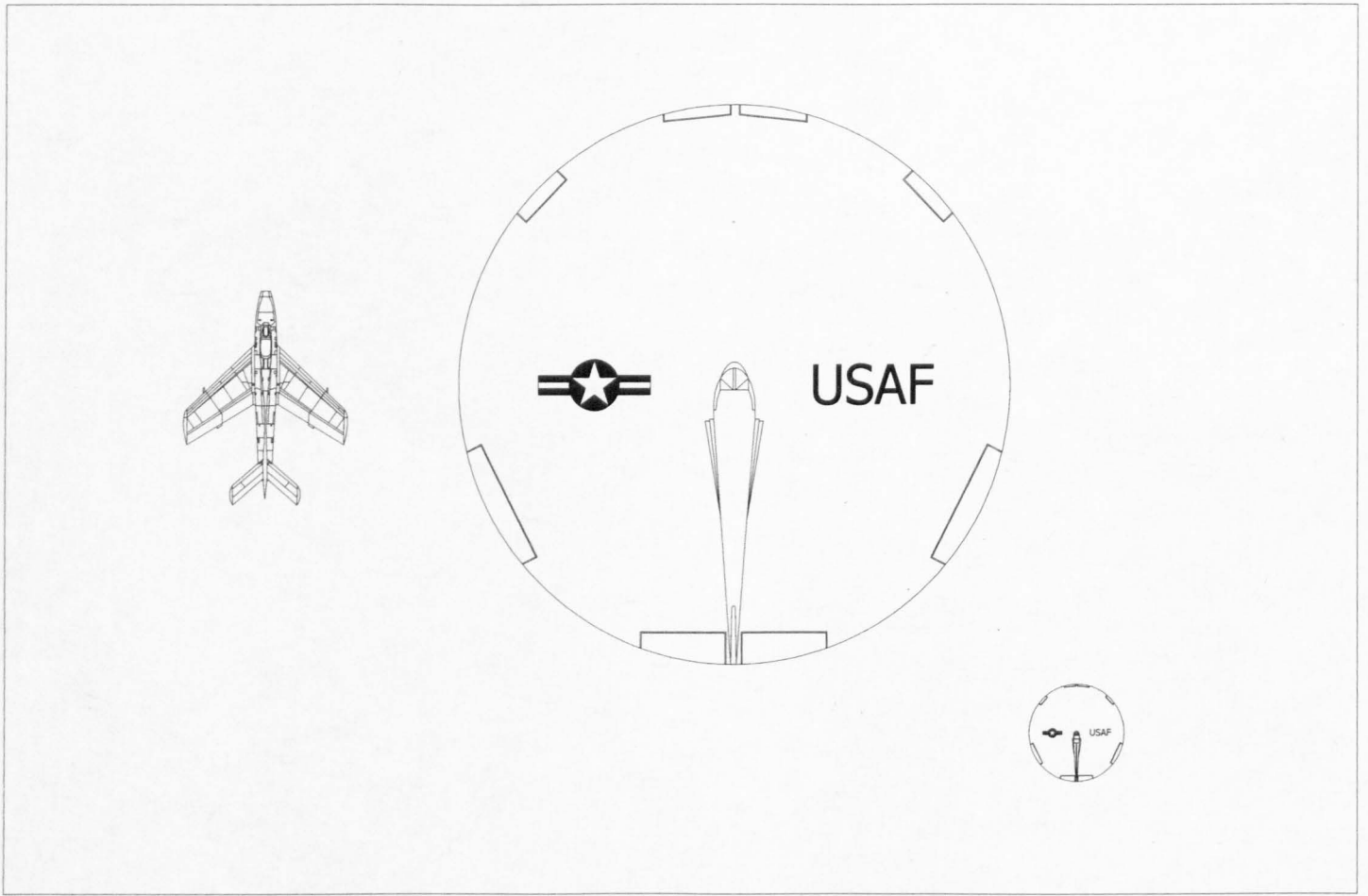

(Illustration #15)

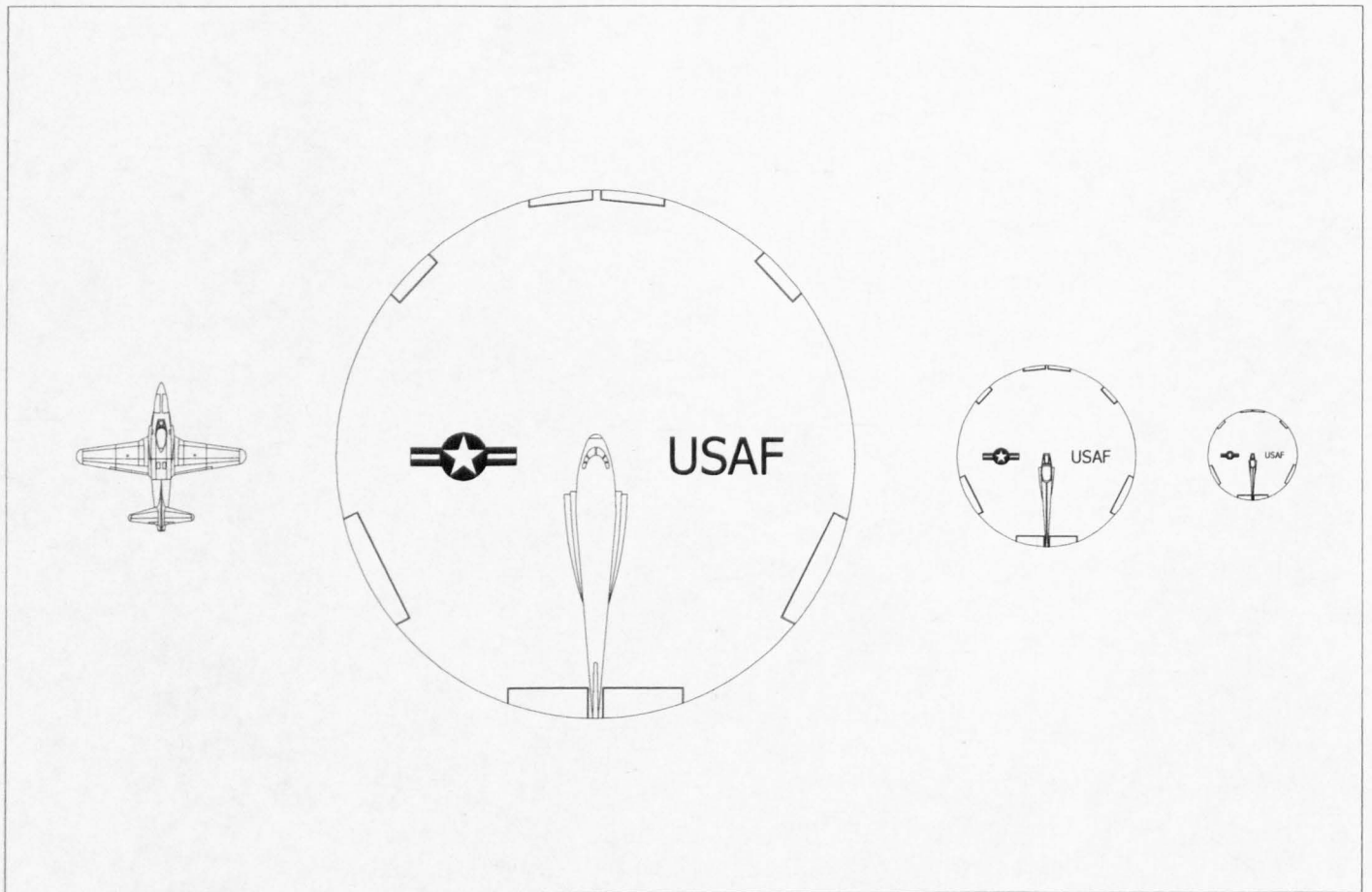

(Illustration #16)

(Illustration #18)

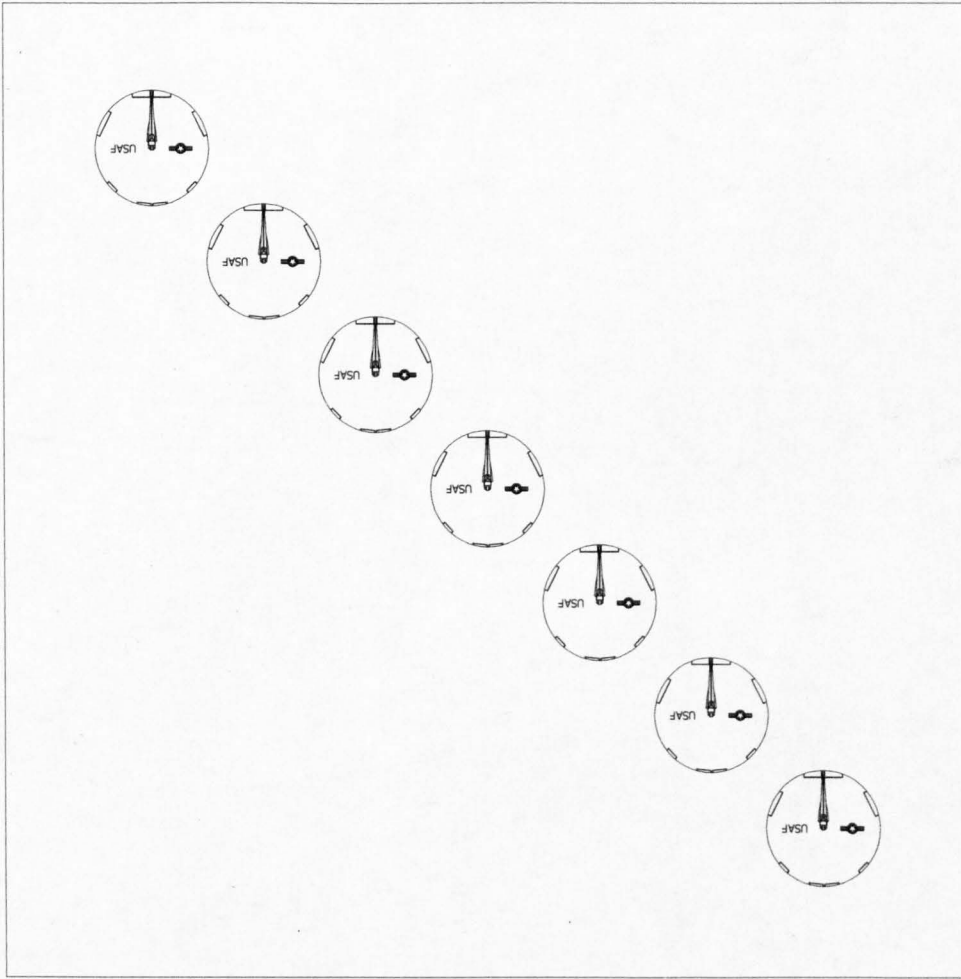

(Illustration #17)

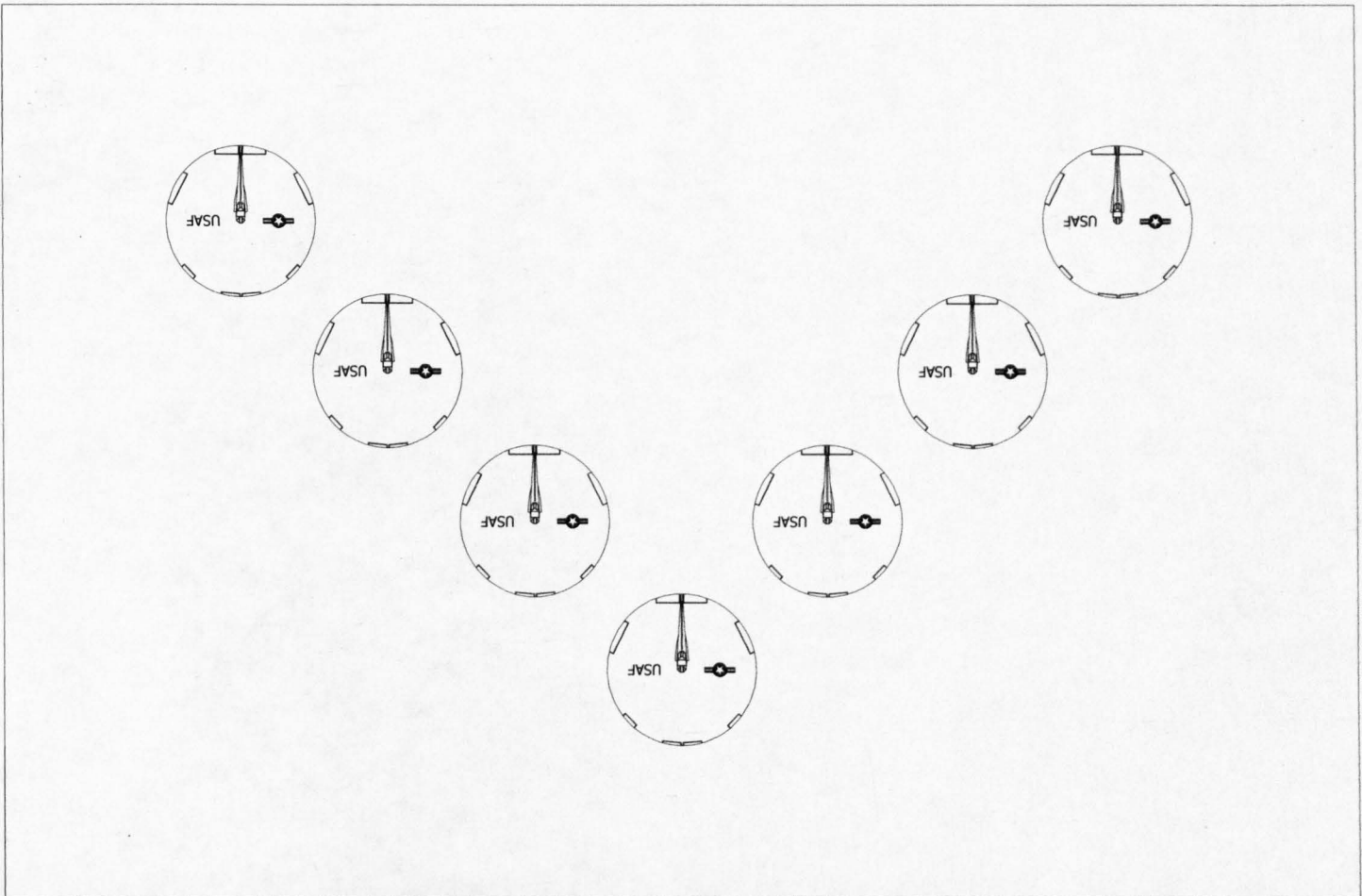



(Illustration #19)





(Illustration #20)



(Illustration #21)



(Illustration #23)





(Illustration #22)

THE LARGE DISC: Measuring 116 feet in diameter (comparable to the wingspan of a B-47 Stratojet), and standing 12' off of the ground, (much higher near the edge) the largest of the four discs must have been a sight to behold (see illustration #6 & #23, #10 background). The O.I.C. permitted Jack to walk under and around this aircraft, but was soon told to come out from under it due to possible safety issues. Jack specifically noted that the port main landing gear of the large craft was partially collapsed, causing the aircraft to lean to the left. Each main landing gear consisted of 6 wheels, measuring 5' in diameter. The nose gear had an incredible 32 wheels, each measuring 2-1/2 to 3 feet in diameter (see illustration #22 & #24). Indeed, Jack recalled that "the front landing gear had more wheels than I had ever seen on any aircraft before". Although all of the tires on this craft were flat, Jack noted that they did not appear exceptionally worn. A door was located on the port side of the craft, for access to the crew compartment. Immediately behind the door, were three oblong rectangular shaped windows that ran along both sides of the fuselage (see illustration #22). These may have been stations for the flight engineer, navigator, and weapon systems operator. The extreme forward section of the crew compartment looked like the nose of a Curtiss C-46 transport aircraft. The large craft employed two air-intakes on both sides of the crew compartment, and four exhaust ports at the aft bottom end of the craft. The air intakes blended beautifully into the sides of the fuselage and upper portion of the disc. It was clear that the crew compartment had room for a pilot and co-pilot who sat side-by-side. The main cabin/fuselage appeared very similar to that of a Douglas DC-6 passenger airliner, with enough room for a central aisle, and two seats on either side. The upper portion of the vertical stabilizer had the designation "U.S." which stood for "Upper Stratosphere"

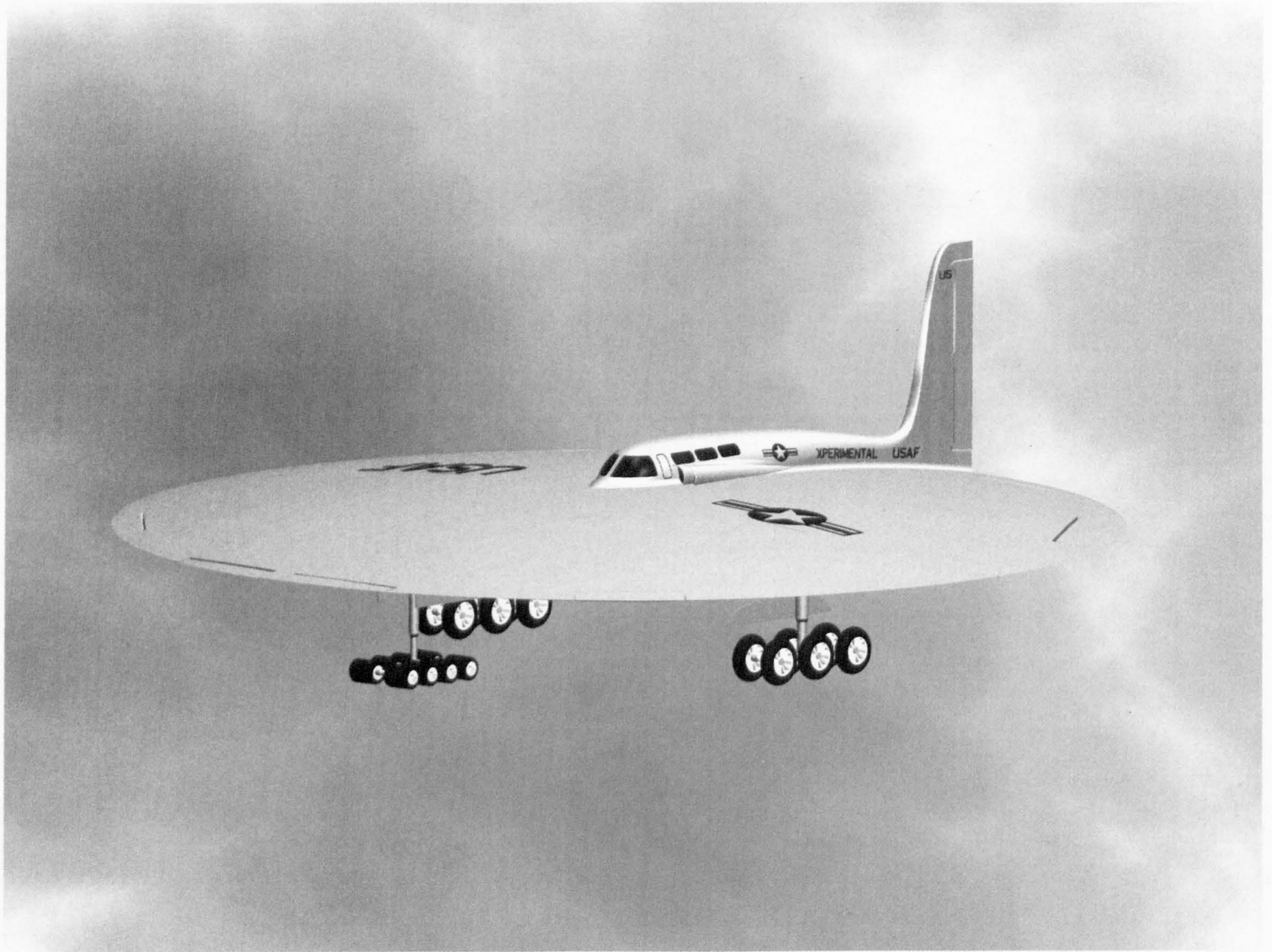

(Illustration #24)

Jack specifically recalls that the unusually high vertical stabilizer was “higher than shopping mall parking lot lights” (see illustration #24 & #25) It was evident that the main landing gear retracted inside the main body of the disc, with the gear moving up and away from the centerline of the aircraft. The nose gear retracted to the rear and up inside the bottom of the disc. Flight control surfaces were located along the circumference of the disc, similar to the 20’ model. Jack remembers seeing what may have been bomb bay doors located on the bottom surface of the disc. These may have been used for the release of 10’ diameter in-flight radio controlled flying wing disc bomb drones. Indeed, Jack remembers seeing flying wing disc drones in various stages of disrepair at the scrap-yard, near the four discs. These bombs were capable of being delivered with “pin-point” accuracy decades before Lockheed F-117 Stealth Fighters dropped “smart bombs” on Iraq during the Gulf War. This indicates that the primary mission for this aircraft may have been that of a long range reconnaissance bomber. The O.I.C. also informed Jack that this aircraft had “nuclear capabilities”. Jack was told that this aircraft regularly over-flew Russia after WWII, but was told: “you can’t print that”. It was obvious to Jack that this large craft would totally die away for the need of long range bombers, escort fighter aircraft, refueling aircraft, support crews, and air bases. What would be the point of manufacturing additional support aircraft, when you had an aircraft that could “do it all”? Of course this would not sit well with the military industrial complex which stands to make billions of dollars manufacturing ordinary run-of-mill support aircraft. This specific point was brought home during President Dwight D. Eisenhower’s farewell address to the nation delivered on January 17th, 1961. President Eisenhower stated that “In the councils of government, we must guard against the acquisition of unwarranted influence, whether sought or unsought, by the military-industrial complex. The potential for the disastrous rise of misplaced power exists and will persist.” This he knew from personal experience, and was well aware that when the military and defense contractors “slept together” bad things happen.

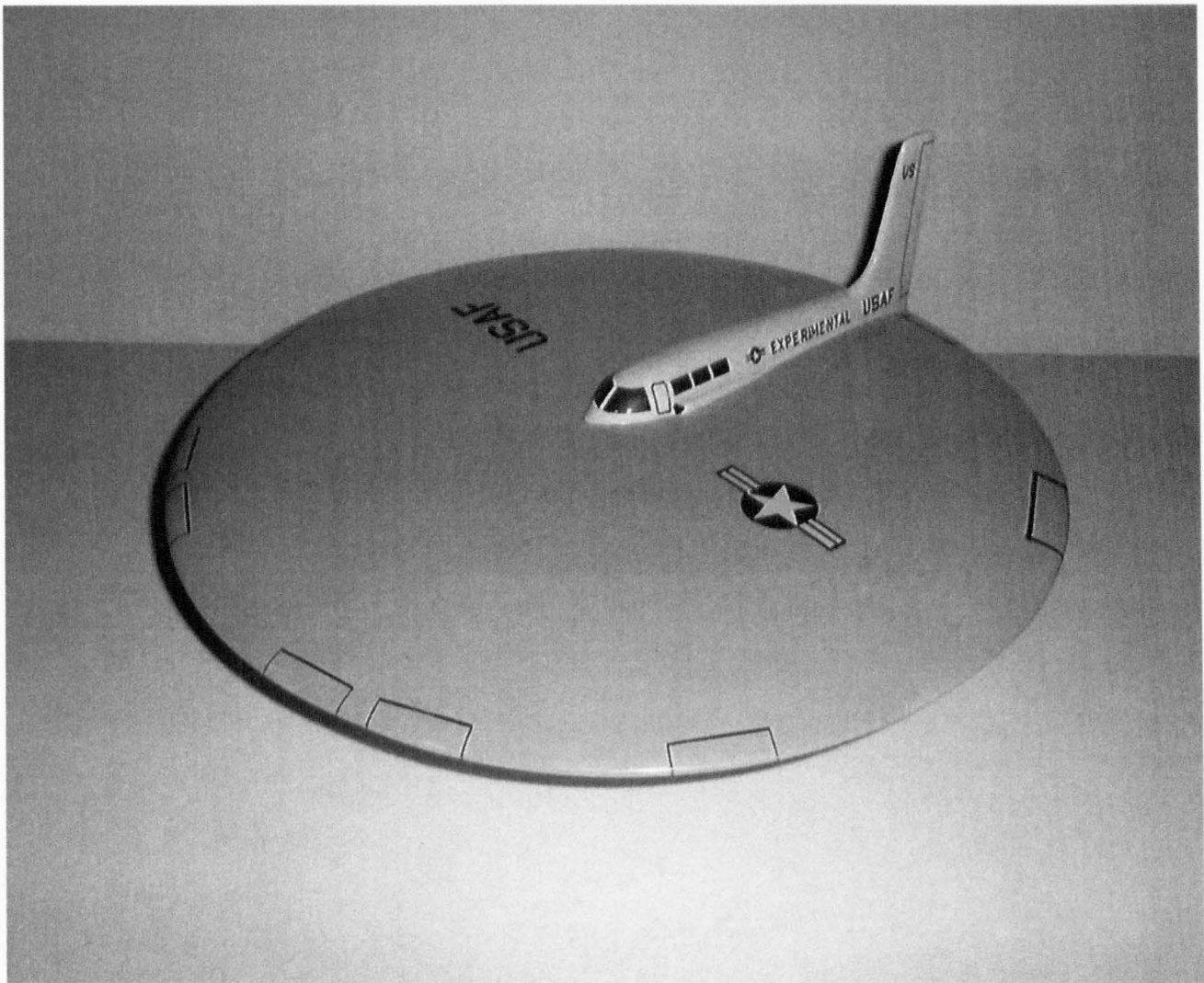

(Illustration #25)

AIRCRAFT PERFORMANCE: When Jack asked the O.I.C. if these were the Flying Saucers everybody was reporting, he was given an affirmative reply. It's clear that what was being reported in the news media as "Flying Saucers" was one of the smaller craft, specifically the 40' diameter model (see illustration #4 foreground, #5, #8, & #9). The overall logistics and tremendous costs involved in manufacturing the giant 116' model may have prevented it from being produced in great quantity (see illustration #6, #26). Jack Pickett was never briefed on the exact propulsion system utilized by the four craft, or who specifically built these aircraft. Due to the fact that low aspect lenticular wing designs are not generally suited for high speed flight, all four aircraft were certainly sub-sonic. Using fighter aircraft flown during the same time period as a guide, (mid 1950's) it's reasonable to conclude that these aircraft had a cruising speed of around 629 mph. Using conventional jet engines, the service ceiling would have been limited to around 60,000 ft., due to their tendency to "flame-out" at extremely high altitudes. Although not having revolutionary performance figures, these aircraft definitely still remain among the utter most classified aircraft in the U.S.A.F. inventory. Jack also inquired why they had been discontinued, and was told that it had to do with maneuverability problems, and that the U.S.A.F. now had "better ones". Jack was also told that some of these discs had been shot down over Russia. Authors special note: Although the following important point seems difficult if not impossible to believe, it has been included into this article for historical purposes. In regards to the specific performance of these aircraft, Jack was told directly by the O.I.C. that "we could fly so fast as to attain sufficient altitude to be classified as achieving space flight". This is consistent with the official USAF classification that space flight begins at an altitude of 50 miles, or approximately 265,000 feet. For Jack's article, the O.I.C. told him that he could state that these aircraft could "exceed mach 1", a very conservative under-statement to say the least. Jack inquired how these aircraft could avoid burning up while descending from such high altitudes. He was told that during re-entry these

aircraft “skip” across the upper portion of the atmosphere, thereby slowing down and dissipating the extreme heat (similar to a flat rock when thrown across a body of water). Jack was also told by the O.I.C. that “had we had different power source engines, we could have gone into orbit” (orbital flight requires 17,500 mph, 25,000 to reach the moon and planets). Jack was also told that these aircraft were more secret than the “Manhattan Project”. Authors special note: Those that are skeptical of the reality of man-made flying saucers would do well to review the sighting made by former Mercury Seven astronaut and test pilot Gordon Cooper. During 1951 in Europe, Gordon Cooper and his squadron-mates attempted to intercept a group of silver saucer shaped craft. Flying their F-86 Saber jets at 45,000 feet, they were unable to catch the discs. Gordon Cooper reported that the discs were flying much higher, and traveling far too fast to be intercepted by his F-86. Colonel Cooper recalled that these discs were seen in flying formations of four and sixteen.

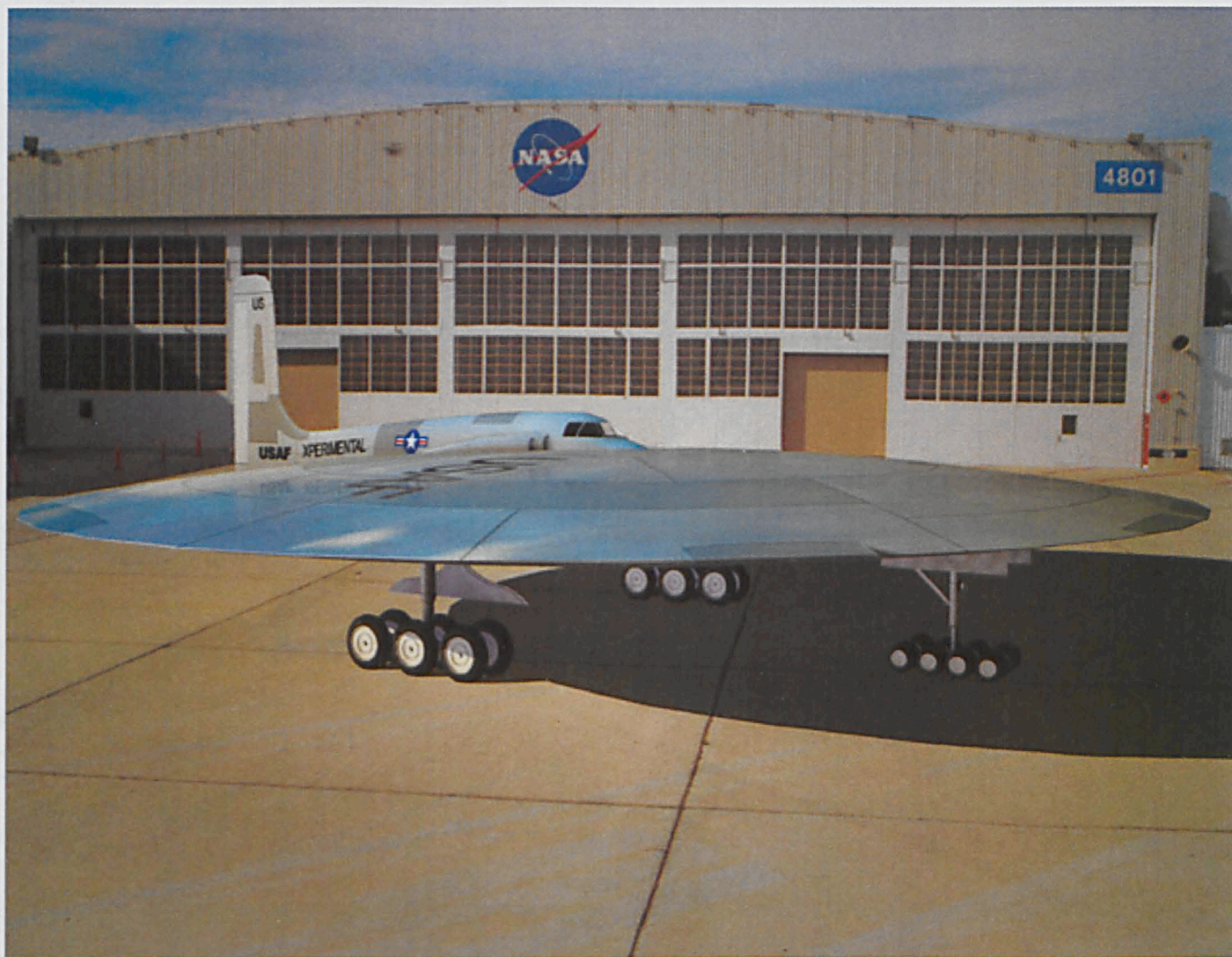

(Illustration #26)

THE PROPOSED ARTICLE: The four disc shaped experimental aircraft were never featured in the October 1967 issue of “NCO Club News”. Coincidentally, while putting that article together, there was a UFO/Flying Saucer sighting which occurred directly over downtown Miami. That particular aircraft Jack was told, originated from Avon Park Air Force Range located 100 miles Southeast of MacDill AFB. Avon Park consisted of runways far too short for the operation of conventional high speed, horizontal take-off aircraft. Only “harrier type” or VTOL aircraft would be ideally suited for operations at this facility. Jack learned that this new prototype developed a propulsion system malfunction, which caused it to drop down to “tree-top level”. The crew was desperately trying to keep the craft airborne long enough to clear Miami so that they could crash land offshore into the Atlantic Ocean. Eventually, the flight crew regained control of the aircraft, which quickly turned straight up, and departed the Miami area at a tremendous speed. It’s entirely possible that a more advanced prototype VTOL variant (possibly Project Silverbug) of the original

four discs stored at MacDill was responsible for the over-fly of Miami. Immediately after the Miami over-fly, Jack bought a copy of the Tampa Tribune morning edition (which carried an article on the sighting), and brought this sighting, which took place approximately on September 20th of 1967 to the attention of the O.I.C. at MacDill, who personally felt that he should make a request to higher Air Force authority for the clearance needed for publication at that time (this sighting was also reported in the Miami Herald). The O.I.C. specifically told Jack "Yes, I know about that aircraft". This was now the making of the biggest and most decisive "catch 22" that the U.S.A.F. ever found itself in. On one hand, the Air Force was standing on the door-step ready to officially release information pertaining to the four discs parked at the scrap-yard which had already been decommissioned/declassified. On the other hand, Jack was told: "*the U.S. Air Force would never admit that aircraft ever existed, never*" (referring to the aircraft that took off from Avon Park, and was responsible for the Miami sighting). Jack was specifically told that it would be in the "better interest of the Air Force" to delay publication of his article. Jack was seated across the desk from the O.I.C. during this meeting. The O.I.C. also possessed the official U.S. Air Force stamp which was ready to go on the back of each of the photos Jack had picked out earlier. Due to the fact that the Air Force had changed their mind, the O.I.C. began taking back the photos. At this exact point, the official declassification of these incredible discs, was officially terminated. Jack was later told that "*Nobody will ever see these aircraft again, until they re-appear as U.S. space craft*" (possible replacement for current space shuttle). Authors special note: During the time that Jack was examining the discs at the scrap-yard, he noticed a hangar nearby. When Jack asked the O.I.C. what was in that hangar, he replied "I'm not going to tell you what's in that hangar". Speculating about the contents of this restricted hangar would be outside the scope of this article. However, it now appears that for what-ever reason MacDill AFB was chosen as a sort of "clearing house" storage facility for Ultra Top Secret Experimental aircraft.

THE CANADIAN CONNECTION: During WWII, Germany had become the undisputed leader in highly advanced aircraft technology. The Me-262 jet interceptor, Horten flying wings, and the Me-163 rocket powered aircraft were decades ahead of allied designs. Under the direction of Dr. Walter Dornberger, the man in charge of operations at Peenemunde, and Dr. Wernher von Braun's boss, a secret saucer program was started at the BMW/Heinkel factory in Dresden in 1943. This design team was headed by Dr. Richard Miethe, who worked for the BMW rocket division in Berlin. Dr Miethe's team was ultimately responsible for the manufacture of the incredible discs that Jack Pickett saw at MacDill AFB in 1967. It can now be revealed, that these discs had been originally built in Germany in the fall of 1943, with the first flight occurring during the spring of 1944. After the close of WWII, many German aeronautical engineers were sent to White Sands Missile Range under "Operation Paperclip". The remaining group of scientists, were captured by the Russians. It can now be revealed that the Soviets reached the German plant in Breslau before the Americans, and quickly dismantled many factories, rebuilding them in Russia. It's clear now that the Soviet Union had it's own saucer program (derived from captured German scientist) which explains many of the over-flights in the United States. Dr. Richard Miethe was sent to Fort Bliss, and later worked at Wright Patterson AFB. Eventually, Dr. Miethe went to work for John C. Frost of the Avro Aircraft Company (a subsidiary of Hawker Siddeley) in Malton Ontario Canada. Mr. Frost was a gifted aircraft designer from England, who headed up Avro's "special projects group" in 1952. Avro was currently working on at least 16 different "Flying Saucer" proposals, including project "Y" and project "Y2" (aka "Project Silverbug"). Project Silverbug was a design for a supersonic VTOL flying disc. By 1953, John frost and his team had completed most of the "paper studies" on these highly unusual aircraft. The only problem facing Mr. Frost, was the overwhelming costs involved in the development of these designs. It quickly became clear that only one country was capable of providing the necessary "financial backing" to "foot the bill" for Avro's flying saucer programs. USAF Lt. General Donald L. Putt had been briefed on the incredible performance specifications of these aircraft, and visited the Avro Canada plant on September 16, 1953. Not wanting this incredible technology to be acquired by any other nation, the U.S.A.F. officially took over and financed Avro's saucer program in late 1954. This allowed the Air Force to "farm out" it's own saucer program on foreign soil, while at the same time keeping the project strategically close to the United States. By 1955, Dr. Miethe had completed construction of the disc shaped aircraft he had originally built in Germany in 1944. These were the exact aircraft reported as "flying Saucers" in the U.S. during 1947. The first test flight of this USAF/Avro disc, occurred in Malton in 1955, with additional test flights taking place at Edwards AFB. Now we know who built the "Flying Saucers" that Jack Pickett saw at MacDill AFB in 1967. Mystery solved!

MYSTERY OF THE LONG RUNWAY : During the close of WWII, General Patton's army came upon a very unusual find at a captured German facility in France (near the V1 and V2 launch sites). Authors special note: This finding was described in Patton's biography which included specific data and photos, and also in an official document known as the "Patton memo" which was shown to Jack Pickett. In fact, General Patton specifically warned the U.S. military of unbelievable facilities being found. General Patton described coming upon a huge runway that was 200 feet wide, 11,300 feet long, and was made of concrete which was 14 feet thick. The memo stated that the runway was built by the Germans using thousands of slave laborers, and took several years to complete. It was his written opinion that the construction materials and labor force "*surpassed that of the great pyramids*" (his words). The runway incorporated a unique feature at the far end. An upward turned "ski slope" was built into the runway to allow larger aircraft with heavy cargo loads to take off more easily. This "ski slope" feature was later incorporated into the designs of British and Russian aircraft carriers. The U.S. constructed such a runway in 1972 for our incoming and outgoing SECRET horizontal take off and landing space craft at Hunter Army Airfield (Savannah GA.) which was never officially closed. In 1972 Jack Pickett visited this facility and contacted the Officer in charge. Jack stood at one end of the runway, and was informed by the O.I.C. that the other end of the runway (which was five miles away) was "off limits". It would seem that this runway also included the "ski slope" feature that was used on the German original. The O.I.C. then dropped a bombshell. He spoke about our secret spacecraft delivering cargo to and from the moon and planets, or "*where ever else we go in outer space*". Authors special note: This statement is consistent with the comments made by Ben Rich, (former head of the famed Lockheed SkunkWorks, and Kelly Johnson's right hand man). During a cocktail party just prior to his death, Ben Rich pulled a few of his close associates aside, and stated: "you know, we already have the technology to travel among the stars, but it's so wrapped up in deep black projects that it would take an act of GOD to get it out to the public".

ENCOUNTER AT WRIGHT PATTERSON AFB: Fortunately, the story doesn't end in 1967. Jack was informed that the four discs parked at the scrap area were the very last of their kind, and were awaiting orders to either be scrapped or flown/transported to Offutt AFB for storage for the yet-to-be-completed Air Force Museum. It has now been confirmed that at least one of these discs had been seen parked on the ramp at Offutt AFB in 1975 by a Federal Government police officer. This brings us to Mr. Warren Botz (retired WWII P-40 Warhawk Flying Tigers pilot) who in 1978 was attending a reunion with his fellow pilots at Wright Patterson AFB. A small group including Warren, were transported by bus across the base to where the restoration hangar is located. It's here that various older aircraft are processed, and made ready for the Air Force Museum. Warren momentarily departed from his group, and managed to walk into a restricted hangar adjacent to the restoration facility (hangar #4 bay "E" see illustration #27 & 28). Taking up the entire hangar, was the identical craft Jack Pickett saw at MacDill AFB in 1967. Through telephone conversations with Mr. Botz, it became apparent that what he saw the large 116' diameter craft (see illustration #30). Warren was only in this hangar for about two minutes, but was able to confirm many of the details mentioned by Jack Pickett 12 years earlier. Mr Botz clearly remembers seeing the tricycle landing gear, along with the very high vertical tail. Warren also recalled that the main landing gear strut "looked as thick as a telephone pole". The nose gear strut was very similar in appearance to that of a French Supersonic Concord. Warren was in this hangar for about two minutes, when a security guard who was stationed near the corner of the hangar "intercepted" him as he was walking towards one of the main landing gear struts. At that point, Warren was politely "escorted" out of the hangar. As he was leaving, Warren was able to look back and get one final look at this "Monster" (his exact word) of an aircraft. In fact, after seeing the illustrations used for this article, Warren declared: "that's the exact aircraft I saw at Wright Patterson AFB". Warren also described that when he entered the hangar where the large disc was being kept, it was parked nose first in the hangar. He went on to describe how the aircraft was towed into the hangar. At first glance, it would appear that the tail was too tall to fit through the hangar opening. Through the use of a special wheeled ramp, the aircraft is rolled inside (see illustration #29). Authors special note: During a telephone interview with Warren Botz, he described the long cabin section as "looking like half of a fuselage". A very important point I never revealed to Warren, but which Jack Pickett stated to me earlier. Jack described the fuselage as looking like someone cut a DC-6 in half horizontally along the centerline, and then "dropped" this section directly on the top portion of the disc.

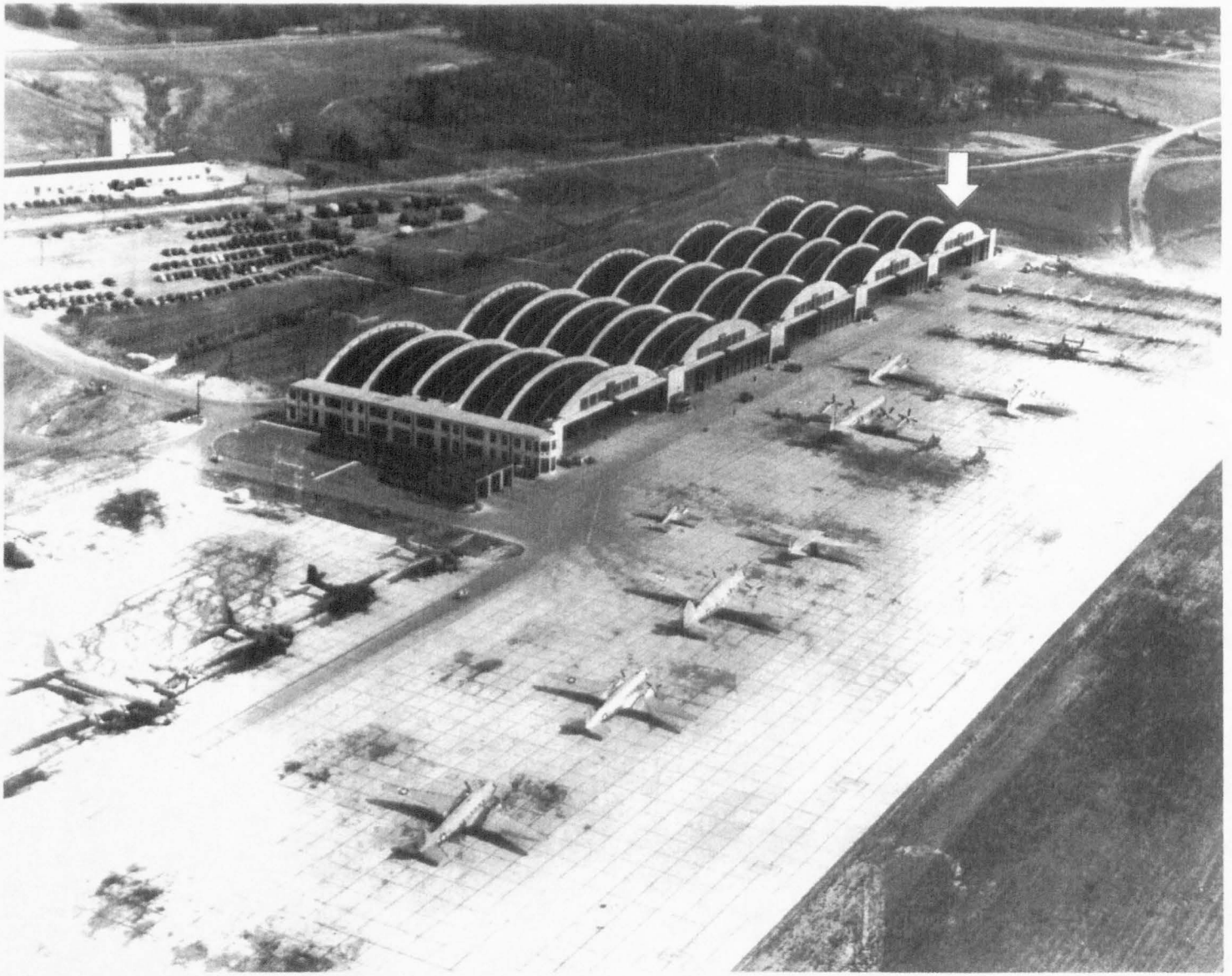

(Picture #27)

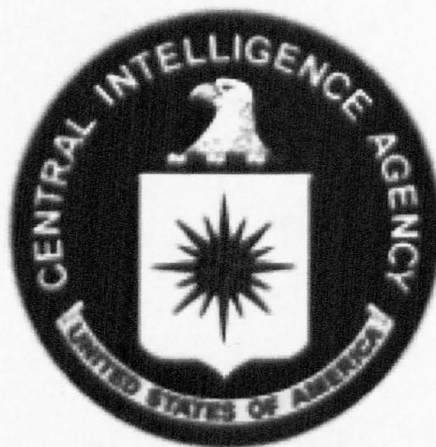



(Picture #28)

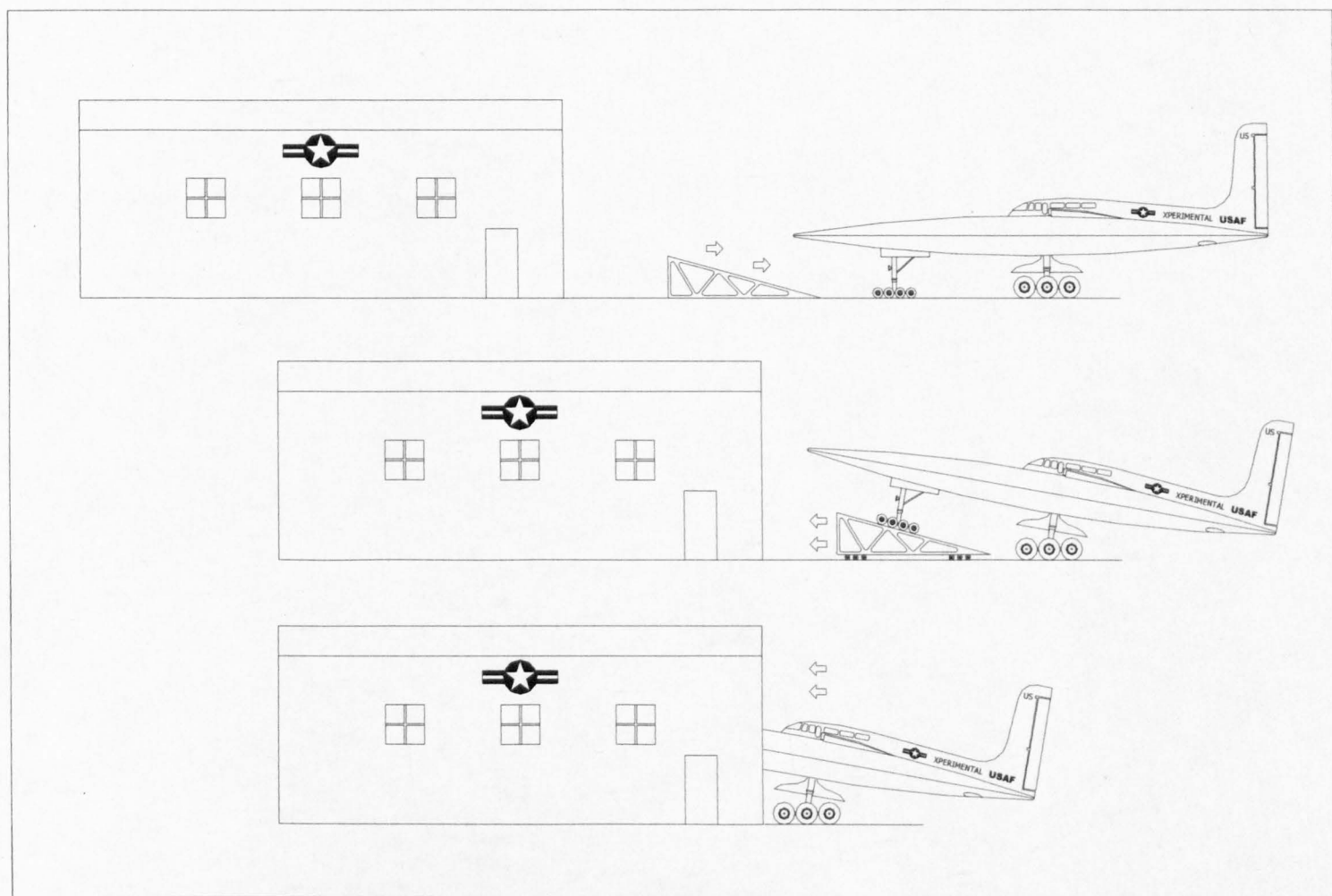

(Illustration #29)

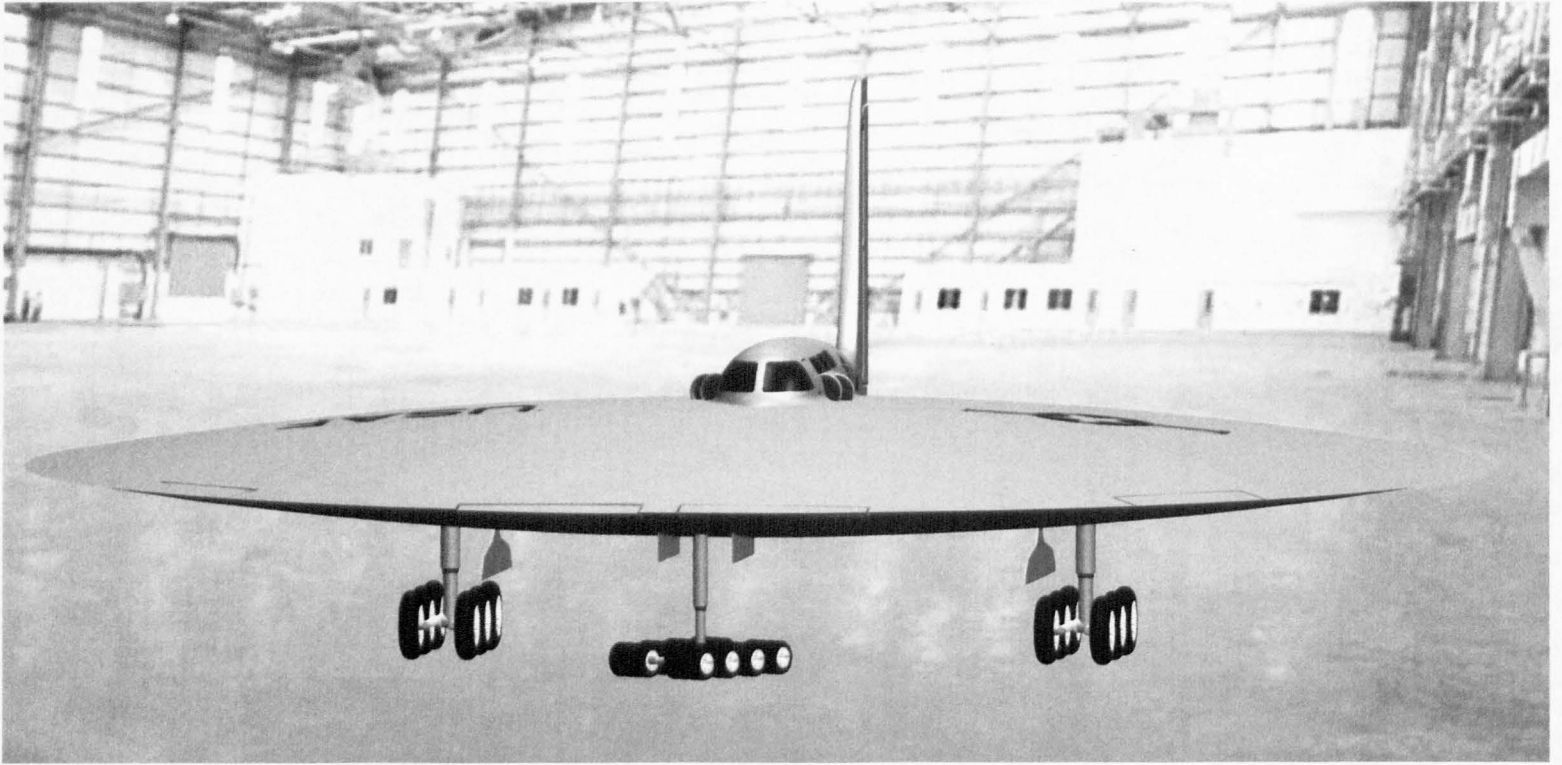

(Illustration #30)

The time has come for the U.S.A.F. to fully declassify and release into public domain, the technical details, photos, and motion picture/newsreel footage pertaining to these specific aircraft. Any potential threat to National Security has now been far out-weighted by the economic and environmental benefits derived from the propulsion systems employed on these aircraft. Indeed, we can no longer as a civilization, go on using obsolete solid and liquid rockets to achieve space flight. There is a "better way" to access space. It's now time for the military industrial complex, and the highest level of U.S. leadership to finally admit that "the game is up", and that the American people, and the world, demand a full disclosure regarding highly classified aerospace vehicles and propulsion systems. Only then, can we all take our rightful place among the stars, and fully reach our potential to discover new worlds, just over the horizon.

Please direct all correspondence to:

Michael H. Schratt
215 Lake Shore Dr.
Crystal Lake IL, 60014

Phone: 630-832-4611
e-mail: auroracad5@aol.com